

LUBRICATE ALL SEALS WITH CLEAN HYDRAULIC OIL PRIOR TO ASSEMBLY.
DO NOT USE SILICONE BASED LUBRICANTS.

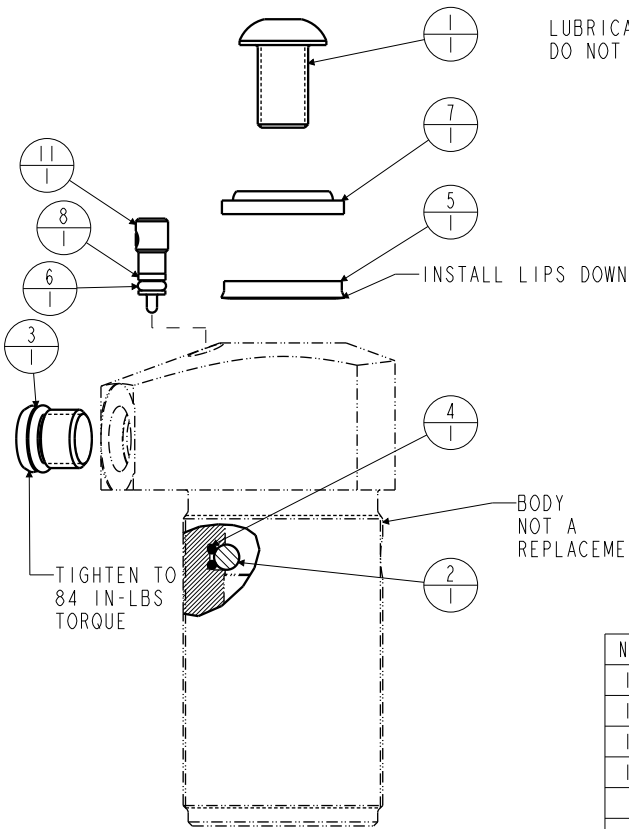

N/A	N/A	60150208	KIT, SEAL, STANDARD	NOTED
13	1	39T55002	GASKET, (-021)	X
12	1	39H10018	SEAL, T, (11/16 X 5/32 X 7/8)	X
11	1	91500900	ASSY, STEM, SC, FC, 1100	
10	1	81530903	RETAINER, SC, DA, 1100, PORTED	
9	1	81510901	PLUNGER, SC, 1100#	
8	1	39054029	BU RING, (-004)	X
7	1	39053001	WIPER, SNAP-IN, (5/8)	X
6	1	39050000	O-RING, (-004)	X
5	1	39010020	SEAL, BEVEL W/HHEEL INSERT, 5/8 x 1/8 x 7/8	X
4	1	39000019	O-RING, (-003)	X
3	1	30601144	PLUG, SOCH, SAE 4	
2	1	23600011	BALL, STEEL, ALLOY, .187	X
1	1	21410009	BHCS, 3/8-24 x 5/8, ALY	
No.	QTY	PART No.	DESCRIPTION	Standard Seal Kit

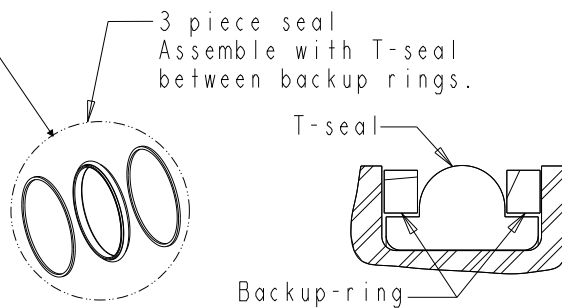
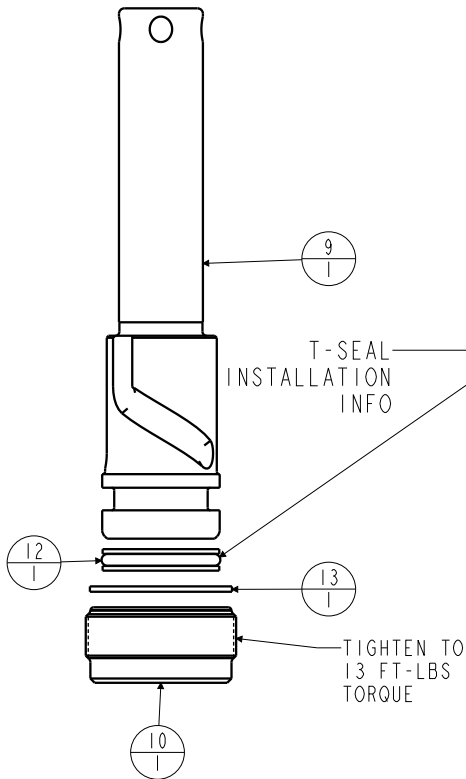

PARTS LIST



VEKTEK, INC.
1334 E. SIXTH AVE. P.O. BOX 625
EMPORIA, KS. 66801 U.S.A.

ASSEMBLIES AFFECTED
15020929

PARTS LIST, ASSY, SC, TB, 1100, FC, DA, BP

SIZE
A PL1572

REV
F

F	5520	RELEASE	JDW	10/04/24
REV	IN ACCORDANCE WITH ECN	EFFECTIVE DATE	REVISED BY	DATE
DRW BY:	BUSH	DRAWING STATUS: Released		
DATE:	08/09/97	PRODUCTION APPROVED FOR RELEASED STATUS ONLY		

FORM FEG035_PL_ASIZE, REV. B

SHEET 1 OF 1